



- 1-channel
- Input EEx ia IIC
- Device installation permissible in zone 2
- 24 V DC supply voltage
- Accuracy 0.1 %
- EMC acc. to NAMUR NE 21

KFD2-RR-Ex1

Function

The KFD2-RR-Ex1 transfers the resistance value (R_m) of a temperature sensor (e. g. Pt100, Pt500, Pt1000, ...) in the 2-, 3- or 4- wire mode. The connection of a converter located in the safe area in the 2-, 3- or 4- wire mode may also be successfully employed.

The converter determines the measurement current (I_m). The current is transferred to the hazardous area by the repeater and causes a voltage drop at the temperature sensor. This voltage is then reproduced in the safe area by the repeater. The present resistance value of the sensor is thereby reproduced at the repeater output. All resistance repeaters are compatible provided measurement current $x (R_m + 900 \Omega) < 10 V$ and measurement voltage $< 7 V$.

Application

As an Ex-isolator between the temperature sensor in the hazardous area and the converter or thermometer in the safe area.

Connection

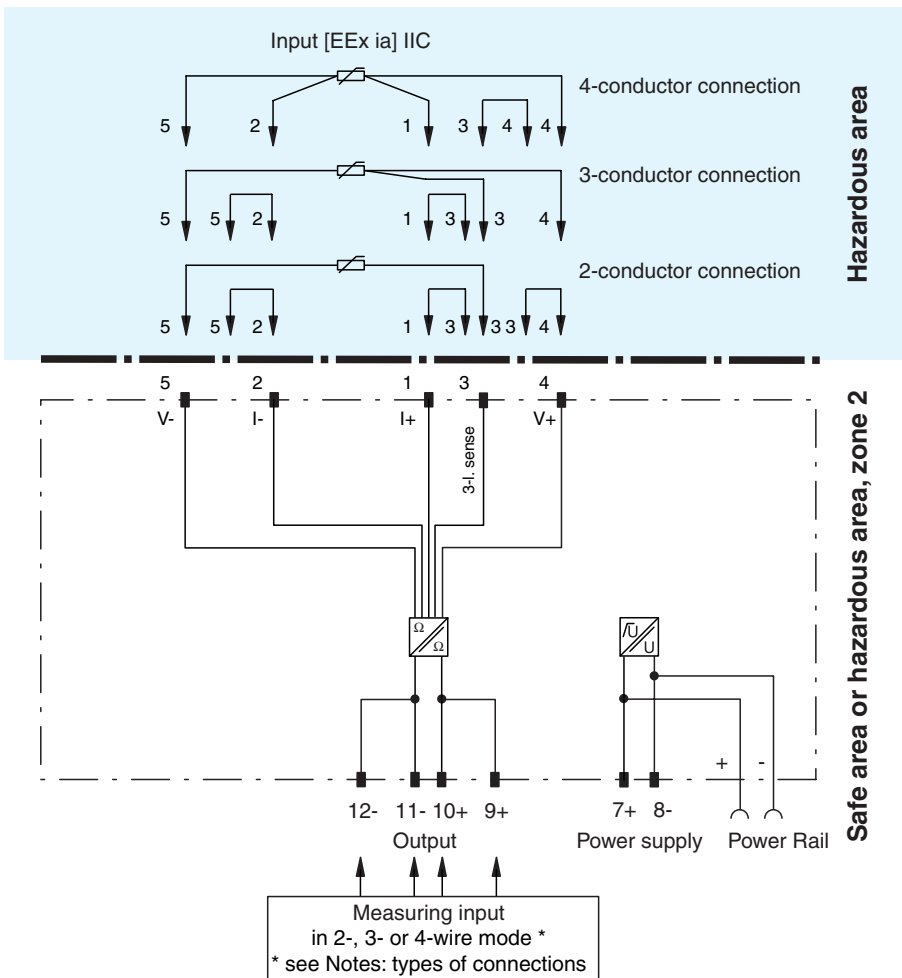



Composition

Front View

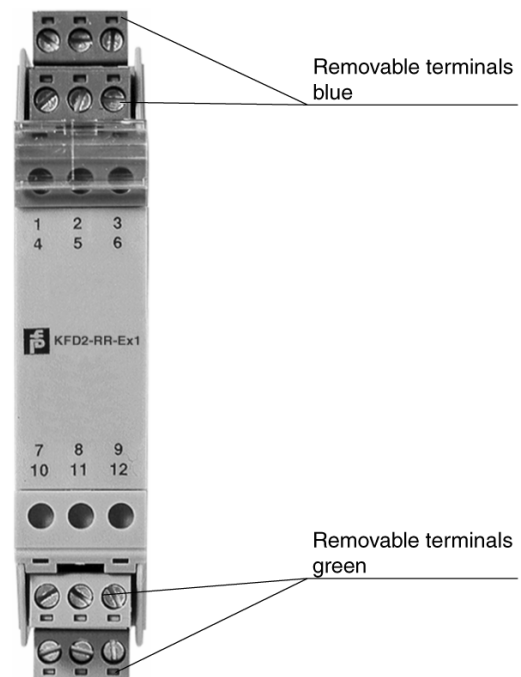
Housing type A4 (see system description)



Release date 2006-03-01 15:39 Date of issue 2006-03-01 127819_ENG.xml

Supply	
Connection	Power Rail or terminals 7+, 8-
Rated voltage	20 ... 35 V DC
Ripple	within the supply tolerance
Rated current	< 20 mA
Power loss	0.25 W (24 V and 1 mA sense current)
Input	
Connection	terminals 1, 2, 3, 4, 5
Lead resistance	≤ 10 % of resistance value
Transmission range	0 ... 10 mA
Available voltage	9 V
Output	
Connection	terminals 12-, 11-, 10+, 9+
Current	0 ... 10 mA
Available voltage	0 ... 7 V
Transfer characteristics	
Deviation	$I_m \geq 1 \text{ mA}$: $\pm 0.1 \%$ of R_m or $\pm 0.1 \Omega$ (the larger value is applicable) $I_m < 1 \text{ mA}$: accuracy reduces in proportion to I_m . e.g. $I_m = 0.1 \text{ mA}$: $\pm 1 \%$ of R_m or 1Ω (the larger value is applicable).
Influence of ambient temperature	$I_m \geq 1 \text{ mA}$, $R_m \geq 100 \Omega$: 0.01% / K in the range $-20 \dots +60 \text{ }^\circ\text{C}$ (253 ... 333 K) $I_m < 1 \text{ mA}$ or $R_m < 100 \Omega$: temperature stability reduces in proportion to I_m or R_m
Rise time	signal response time $\leq 2 \text{ ms}$ (10 ... 90 %) response to application of I_m : $R_m > 50 \Omega$ and $I_m < 5 \text{ mA}$: $< 5 \text{ ms}$ response to application of I_m : $R_m > 30 \Omega$ and $I_m < 5 \text{ mA}$: $< 10 \text{ ms}$ response to application of I_m : $R_m > 18 \Omega$ and $I_m < 5 \text{ mA}$: $< 20 \text{ ms}$
Electrical isolation	
Output/power supply	basic insulation acc. to EN 50178, rated insulation voltage of 50 V AC
Directive conformity	
Electromagnetic compatibility	
Directive 89/336/EC	EN 50081-2, EN 50082-2, IEC 801-2 and IEC 801-4 ... 6
Conformity	
Insulation coordination	EN 50178
Electrical isolation	EN 50178
Electromagnetic compatibility	NE 21
Protection degree	IEC 60529
Ambient conditions	
Ambient temperature	$-20 \dots 60 \text{ }^\circ\text{C}$ (253 ... 333 K)
Mechanical specifications	
Protection degree	IP20
Mass	approx. 100 g
Dimensions	20 x 107 x 115 mm (0.8 x 4.2 x 4.5 in)
Data for application in conjunction with hazardous areas	
EC-Type Examination Certificate	BAS 01 ATEX 7282 , for additional certificates see www.pepperl-fuchs.com
Group, category, type of protection	 II (1) G D [Ex ia] IIC ($-20 \text{ }^\circ\text{C} \leq T_{\text{amb}} \leq 60 \text{ }^\circ\text{C}$)
Voltage U_0	12.4 V
Current I_0	17 mA
Power P_0	53 mW
Supply	
Safety maximum voltage U_m	250 V (Attention! The rated voltage can be lower.)
Type of protection [Ex ia]	
Explosion group	IIA IIB IIC
External capacitance	30 μF 7.9 μF 1.24 μF
External inductance	855 mH 458 mH 120 mH
Output	
Safety maximum voltage U_m	250 V (Attention! The rated voltage can be lower.)
Statement of conformity	TÜV 99 ATEX 1499 X , observe statement of conformity
Group, category, type of protection, temperature classification	 II 3 G EEx nA II T4
Electrical isolation	
Input/output	safe electrical isolation acc. to EN 50020, voltage peak value 375 V
Input/power supply	safe electrical isolation acc. to EN 50020, voltage peak value 375 V
Directive conformity	
Directive 94/9 EC	EN 50014, EN 50020, EN 50021
Entity parameter	
Certification number	4Z6A5.AX

Release date 2006-03-01 15:39 Date of issue 2006-03-01 127819_ENG.xml

FM control drawing	No. 116-0129		
Suitable for installation in division 2	yes		
Connection	terminals 1, 2, 3, 4, 5		
Input I			
Current I_t	17.4 mA		
Voltage V_t	12.8 V		
Explosion group	A&B	C&E	D, F&G
Max. external capacitance C_a	1.33 μ F	3.99 μ F	10.64 μ F
Max. external inductance L_a	108.6 mH	381.1 mH	957.8 mH
Safety parameter			
CSA control drawing	LR 65756-13		
Control drawing	No. 116-0132		
Connection	terminals 1, 2, 3, 4, 5		
Input I			
Voltage V_{OC}	11.6 V		
Current I_{SC}	15.6 mA		
Explosion group	A&B	C&E	D, F&G
Max. external capacitance C_a	1.8 μ F	5.6 μ F	15 μ F
Max. external inductance L_a	1000 mH	1000 mH	1000 mH

Supplementary information

EC-Type Examination Certificate, Statement of Conformity, Declaration of Conformity and instructions have to be observed. For information see www.pepperl-fuchs.com.

Notes

Connection types:

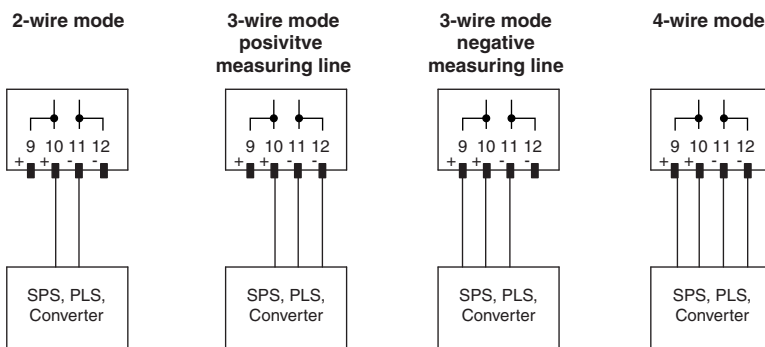

In the case of fast multiplex input cards, transmission problems might be experienced in connection with low resistance values and/or high sensor currents. For data see Rise Time

Measurement range:

The isolated transformer can convey a maximum of 10 mA and a maximum of 7 V. The maximum transferable resistance value can be derived from the following equation:

$$\text{Resistance value} = 7 \text{ V/sensing current}$$

The sensing current is determined by the original Non-Ex converter.

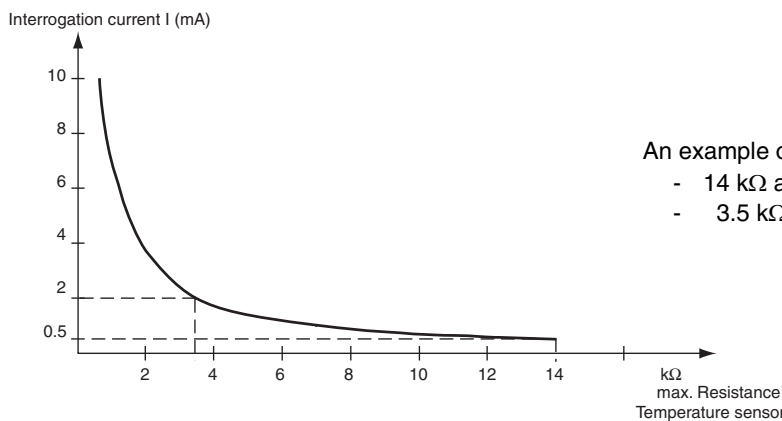

An example of the maximum transferable resistance value:

- 14 kΩ at 0.5 mA sensing current
- 3.5 kΩ at 2 mA sensing current

Accessories

Power Rail PR-03

Power Rail UPR-03

Power feed module KFD2-EB2...

Using Power Rail PR-03 or UPR-03 the devices are supplied with 24 V DC by means of the power feed modules. If no Power Rails are used, power supply of the individual devices is possible directly via their device terminals.

Each power feed module is used for fusing and monitoring groups with up to 100 individual devices. The Power Rail PR-03 is an inset component for the DIN rail. The Power Rail UPR-03 is a complete unit consisting of the electrical inset and an aluminium profile rail 35 mm x 15 mm x 2000 mm. To make electrical contact, the devices are simply engaged.

The Power Rail must not be fed via the device terminals of the individual devices!